

# ART. 02024MS21259

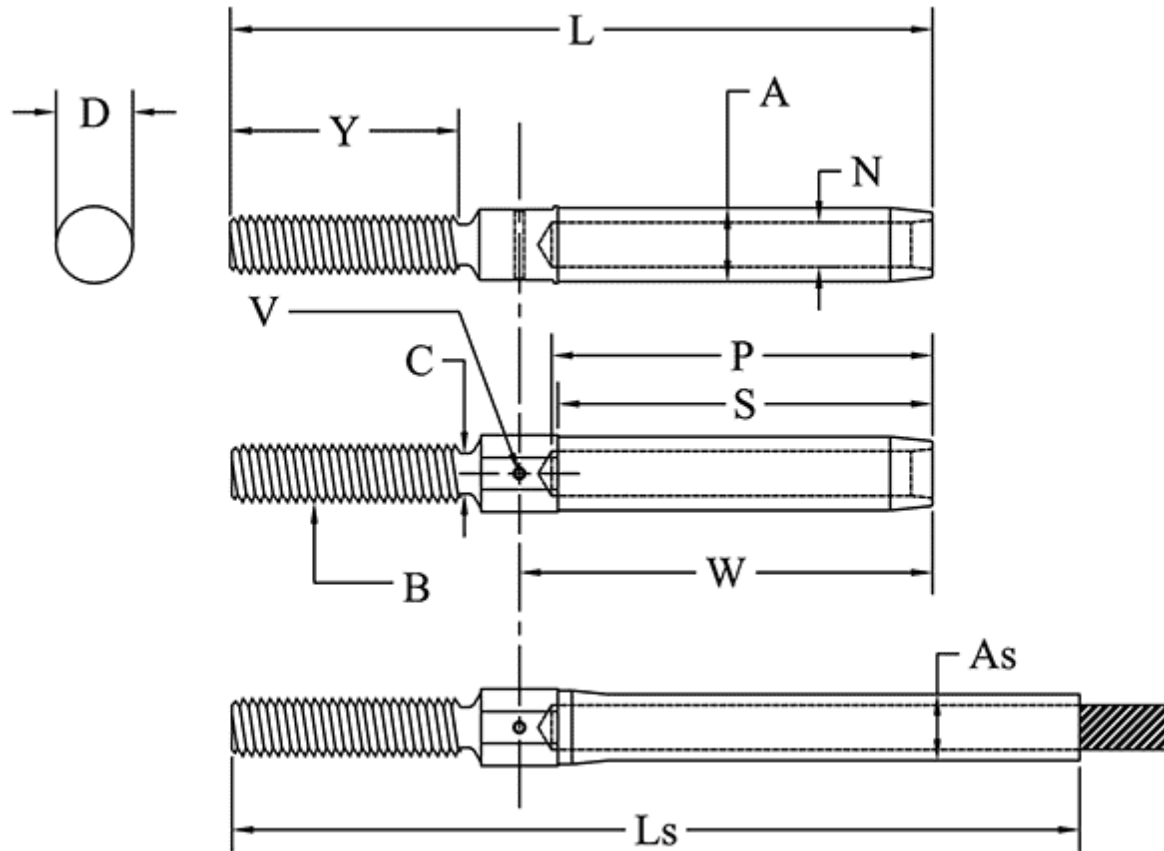

Parte MS Filettatura RH	Parte MS Filettatura LH	Cavo Dia.	Filetto B UN-3A UNF-3A	A Dia	Come Dia	C Dia	D	L ±.063	Ls Rif.	N Dia
MS21259-2RH	MS21259-2LH	1/16	(#6)-40	0.16	0.138	0.121	0.188	2.473	2.65	0.078
MS21259-3RH	MS21259-3LH	3/32	(#10)-32	0.218	0.19	0.169	0.25	2.879	3	0.109
MS21259-4RH	MS21259-4LH	1/8	(1/4)-28	0.25	0.219	0.226	0.313	3.333	3.59	0.141
MS21259-5RH	MS21259-5LH	5/32	(1/4)-28	0.297	0.25	0.226	0.313	3.627	3.97	0.172
MS21259-6RH	MS21259-6LH	3/16	(5/16)-24	0.359	0.313	0.285	0.375	4.002	4.17	0.203

Parte MS Filettatura RH	Parte MS Filettatura LH	Diametro del cavo.	Filetto B UN-3A UNF-3A	P	V +.005 -0.000	S +.062 -0.000	W ±.016	Y +.083 -0.020	Libbre. Per Pezzo
MS21259-2RH	MS21259-2LH	1/16	(#6)-40	1.042	0.063	0.969	1.174	1.045	0.01
MS21259-3RH	MS21259-3LH	3/32	(#10)-32	1.261	0.063	1.188	1.411	1.204	0.0225
MS21259-4RH	MS21259-4LH	1/8	(1/4)-28	1.511	0.063	1.438	1.682	1.376	0.0375
MS21259-5RH	MS21259-5LH	5/32	(1/4)-28	1.761	0.063	1.688	1.958	1.376	0.0475
MS21259-6RH	MS21259-6LH	3/16	(5/16)-24	2.011	0.098	1.938	2.237	1.458	0.08